

CD40522



Ice Form



CUBE

FULL CUBE DIMENSIONS

W x D x H (mm)	22 x 22 x 22
----------------	--------------

HALF CUBE DIMENSIONS

W x D x H (mm)	22 x 22 x 10
----------------	--------------

Features

- Only 559 mm wide.
- Only 1935 mm tall with ICE series machine.
- ARI Storage (54 kg) of ice.
- Turbo Dispense.
- Power Clean allows access to the bin for easy cleaning without moving the ice machine. Interlock safety switch turns off machine agitation when top-front access panel is removed.
- 102 mm foam insulation for maximum ice preservation - no more quick melting ice.
- Constructed from corrosion-resistant stainless steel and fingerprint-proof plastic.

Space-saving Solutions

- Great for hard water, food safety and tight spaces.
- Ultra-low profile design.
- Maximum ice storage in a minimum amount of space.
- User friendly push-to-dispense operation.

CD40522 shown with ICE0320 (sold separately).

Ice Production for Optional Cube Ice Makers

Model	ICE0325	ICE0525
Air-Cooled	137 kg	254 kg
Voltage Char.	220-240/50/1	220-240/50/1

Tested at 21°C Air/10°C Water.

*Kilograms per 24 hours.

** All specifications and performance data are subject to normal manufacturing variances.

CD40522

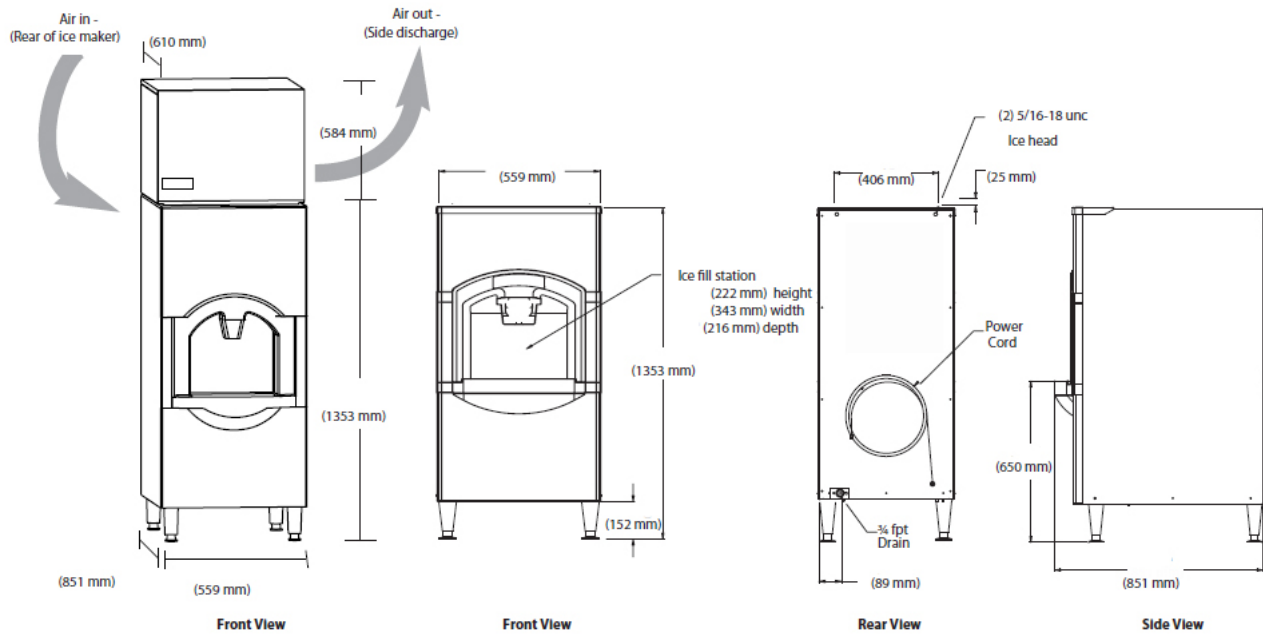

Dimensions

Model CD40522

W x D x H (mm)
559 x 851 x 1353

Specifications

Model	Dispenser Operation	ARI Bin Storage	Voltage Characteristics	Min, Circuit Ampacity
CD40522	Push	55 kg	230/50/1	2.1

Notes

- Model CD40522 dispensers accept all 22 inch ICE Series Cube Ice Makers.
- CD40522 Series units do not require an adapter and Bin Level Kit.
- Number of wires: 3 (including ground)
- Approx. Shipping Weight: 105 kg.