



# 7 Series ice and water dispenser with Chewblet ice machine

countertop and freestanding

## Features

Compact size, only 17.6" (45 cm) tall to fit on counters under standard cabinets

7 lb (3.2 kg) ice storage capacity

Integral air-cooled ice machine with up to 125 lb (57 kg) daily production of popular Chewblet® ice

- designed to serve up to 25 people (140 servings per 10 hr day<sup>1</sup>)
- soft, chewable, compressed nugget ice is preferred over cubes<sup>2</sup>
- environmentally responsible R134a refrigerant with zero ozone depletion potential
- energy saving sleep mode
- quiet production without noisy harvest cycles

Durable, attractive dispenser

- modern styling, stainless steel exterior with accent trim
- dispense-activated soft blue light illuminates point-of-use
- easy-to-clean, removable 20 oz (591 ml) drip tray
- dispenser top can support 35 lbs (16 kg)

Designed with sanitation in mind

- Agion® silver-based antimicrobial product protection of key ice and water contact components<sup>3</sup>
- sanitary ice dispense reduces chance of contamination

Installation

- comes fully assembled
- two easy connections – electric and water
- drainless design allows dispenser to be placed anywhere a water line can be run and eliminates the cost of a drain installation

**NOTE:** For use in applications with less than 400 mg/l total dissolved solids in water and less than 200 mg/l hardness (either naturally occurring or treated with reverse osmosis or other TDS reducing technology). Not recommended for use with softened water.



## Accessories

Base stand for converting countertop models (item# 00956292)

4" (10 cm) leg kit for CI - countertop models (item# 00956300)

6" (15 cm) leg kit for FS - freestanding models (item# 00956318)

Drip tray drain kit for countertop models (includes 4" (10 cm) legs) (item# 00981977)

Drip tray drain kit for models other than countertop (item# 00956375)

Ice machine cleaning and sanitizing kit, single use (item# 00989856)

Cartridge, replacement 5 micron particle/carbon (item# 00968107)

Claris<sup>4</sup> hardness removal filtration system (item# 00986059)

Reverse osmosis system, 200 gallons (757 L) per day (item# 00986034)

115 V 60 Hz – ice and water dispensers			
Ice storage capacity	Configuration	Filter*	Item number
<b>7 lb (3.2 kg)</b>	countertop	no filter	<b>7CI100A-IW-NF-ST-00</b>
		internal	<b>7CI100A-IW-CF-ST-00</b>
	freestanding	no filter	<b>7FS100A-IW-NF-ST-00</b>
		internal	<b>7FS100A-IW-CF-ST-00</b>

Ice-only available, replace IW with NW – Example 7FS100A-NW-NF-ST-00

\* Internal filter is a 5 micron particle and carbon filter

Job

Item

## Specification

Ice storage capacity	7 lbs (3 kg)
<b>W1</b> Width	14.6" (37 cm)
<b>D1</b> Depth	22.1" (56 cm)
<b>H1</b> Height – countertop models	17.6" (45 cm)
<b>H2</b> Height – freestanding models	42.0" (107 cm)
<b>H3</b> Height, base stand	24.4" (62 cm)
<b>H4</b> Dispense height clearance	8.0" (20 cm)
Ventilation clearance	3" (76 mm) on each side
Service clearance	3" (76 mm) behind and on each side of dispenser
<b>C1</b> Electrical – 115 V, 60 Hz	115 V, 60 Hz – 1 phase, 5 amps. Connect to dedicated 15 amp circuit, fuse or breaker. 8' (2.4 m) cord w/ NEMA 5-15 90° plug. If local code requires hard-wiring, separate disconnects also required. NOTE: It is preferred that circuit be protected by a GFCI.
<b>C2</b> Water inlet	1/4" MPT
Air temperature	50 - 100 F (10 - 38 C)
Water temperature	40 - 90 F (4 - 32 C)
Water pressure	10 - 70 psi (69 - 483 kpa)
Ice production at 70 F (21 C) air and 50 F (10 C) water	125 lbs (57 kg)
Ice production at 90 F (32 C) air and 70 F (21 C) water	100 lbs (45.4 kg)
Energy consumption 90 F (32 C) air and 70 F (21 C) water	6.9 kWh per 100 lbs (45.4 kg) ice
Heat rejection	1700 BTU/hr
Water consumption	12 gal (45.4 L) of potable water per 100 lbs (45.4 kg) of ice
Approximate shipping weight – countertop models	90 lb (41 kg)
Approximate shipping weight – freestanding models	120 lb (54 kg)

NOTE: For indoor use only. Designed for commercial use. Follett is not able to provide in-house services for residential installations.

SHORT FORM SPECIFICATION: (Choose one) \_\_\_ Ice and water or \_\_\_ ice-only dispenser to be Follett automatic load in (choose one) \_\_\_ countertop or \_\_\_ freestanding configuration, with 7 lbs (3 kg) of storage. Environmentally responsible R134a ice machine to be air-cooled. Ice machine to produce approximately 125 lbs (57 kg) of Chewblet compressed nugget ice at air temperature of 70 F (21 C) and water temperature of 50 F (10 C). Ice machine to be equipped with printed circuit board and diagnostics to allow simplified servicing and with capacitive touch user interface. Storage area to be insulated with non-CFC, high density foam-in-place polyurethane. 115 V, 60 Hz, 1 phase. 8' (2.4 m) cord and NEMA 5-15 90° plug provided. Dispenser to be NSF and ETL listed. Total dissolved solids in water not to exceed 400 mg/l (ppm) and hardness not to exceed 200 mg/l (ppm).

## Dimensional drawing

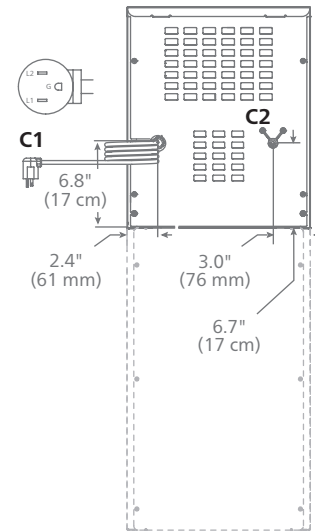
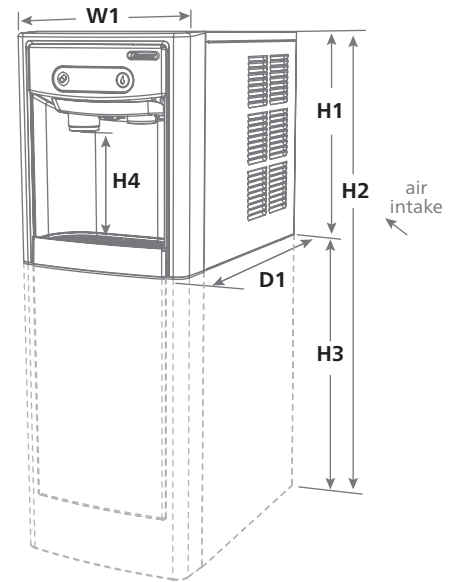

- 16 oz (473 ml) cups, 2/3 full of ice
- Independent third party studies. Contact Follett for details.
- Disclaimer: Antimicrobial protection is limited to the treated components and does not treat water or ice.
- Claris is a registered trademark of the Aquis GmbH in Switzerland.  
Agion is a registered trademark of Sciessent LLC.  
SafeCLEAN is a trademark of Follett Corporation.  
Chewblet and Follett are registered trademarks of Follett Corporation, registered in the US.  
Follett reserves the right to change specifications at any time without obligation. Certifications may vary depending on country of origin.